

LH531000B-S

CMOS 1M (128K × 8)
3 V-Drive Mask-Programmable ROM

FEATURES

- 131,072 words × 8 bit organization
- Access time: 500 ns (MAX.)
- Power consumption:
 - Operating: 64.8 mW (MAX.)
 - Standby: 108 μW (MAX.)
- Mask-programmable control pin:
Pin 20 = $\overline{CE/OE/OE}$
- Static operation
- Three-state outputs
- Low power supply: 2.6 V to 3.6 V
- Package: 28-pin, 450-mil SOP

DESCRIPTION

The LH531000B-S is a mask-programmable ROM organized as 131,072 × 8 bits. It is fabricated using silicon-gate CMOS process technology.

PIN CONNECTIONS

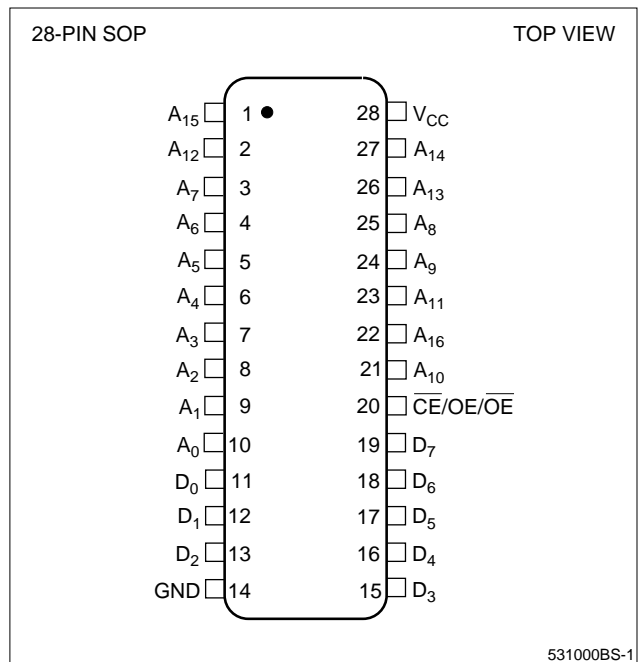
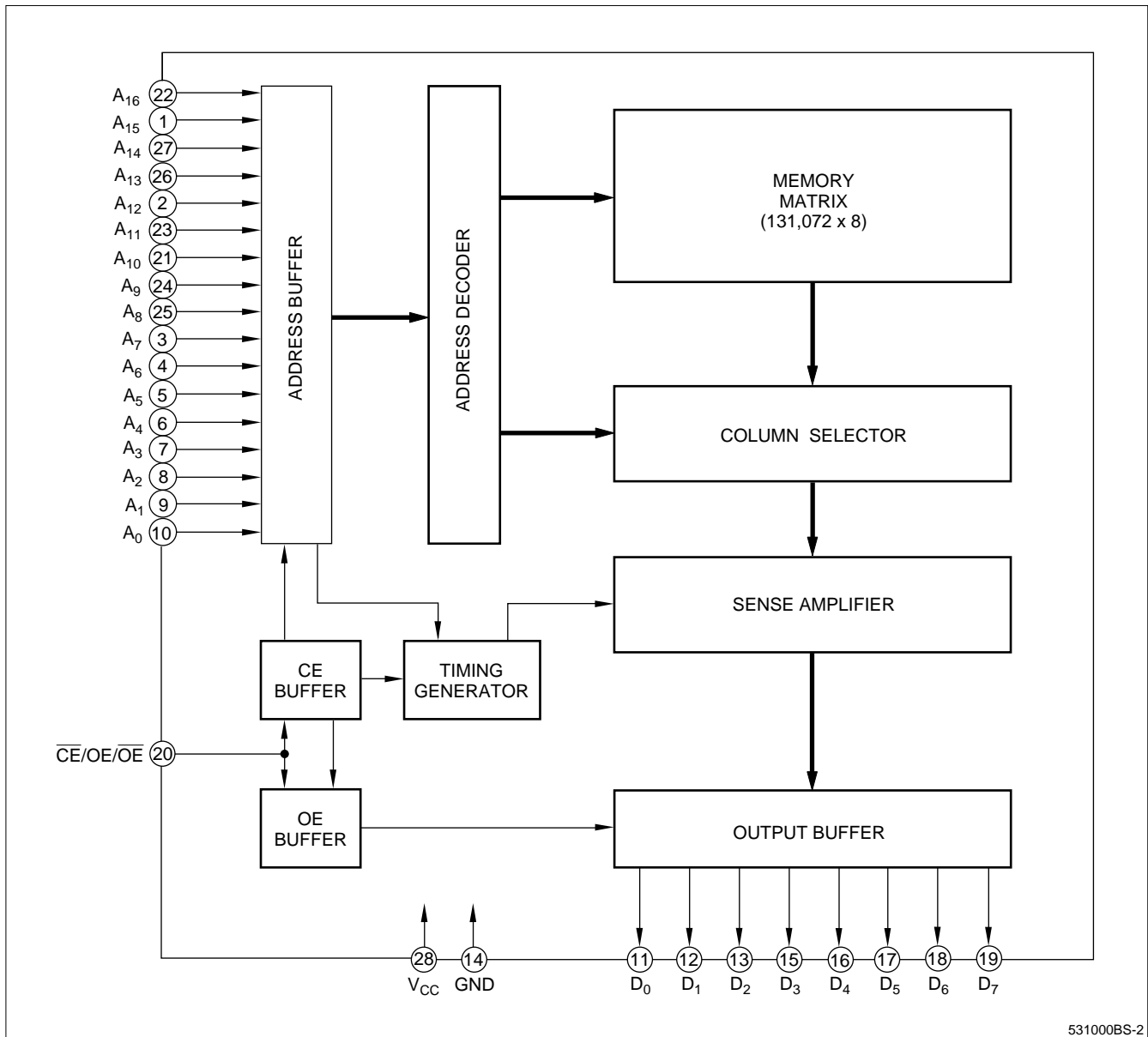

Figure 1. Pin Connections for DIP Package



531000BS-2

Figure 2. LH531000B-S Block Diagram

PIN DESCRIPTION

SIGNAL	PIN NAME	NOTE
A ₀ – A ₁₆	Address input	
D ₀ – D ₇	Data output	
$\overline{CE/OE/OE}$	Chip Enable input or Output Enable input	1

SIGNAL	PIN NAME	NOTE
V _{CC}	Power supply (2.6 V to 3.6 V)	
GND	Ground	

NOTE:

1. Active level of $\overline{CE/OE/OE}$ is mask-programmable.

TRUTH TABLE

\overline{CE}	OE/\overline{OE}	MODE	SUPPLY CURRENT
H	–	High-Z	Standby
L	–	Output	Operating
–	L/H	High-Z	Operating
–	H/L	Output	

ABSOLUTE MAXIMUM RATINGS

PARAMETER	SYMBOL	RATING	UNIT
Supply voltage	V_{CC}	–0.3 to +7.0	V
Input voltage	V_{IN}	–0.3 to $V_{CC} + 0.3$	V
Output voltage	V_{OUT}	–0.3 to $V_{CC} + 0.3$	V
Operating temperature	T_{opr}	0 to +70	°C
Storage temperature	T_{stg}	–65 to +150	°C

RECOMMENDED OPERATING CONDITIONS ($T_A = 0^\circ\text{C}$ to $+70^\circ\text{C}$)

PARAMETER	SYMBOL	MIN.	TYP.	MAX.	UNIT
Supply voltage	V_{CC}	2.6		3.6	V

DC CHARACTERISTICS ($V_{CC} = 2.6\text{ V}$ to 3.6 V , $T_A = 0^\circ\text{C}$ to $+70^\circ\text{C}$)

PARAMETER	SYMBOL	CONDITIONS	MIN.	TYP.	MAX.	UNIT	NOTE
Input 'Low' voltage	V_{IL}		–0.3		0.4	V	
Input 'High' voltage	V_{IH}		$0.8 \times V_{CC}$		$V_{CC} + 0.3$	V	
Output 'Low' voltage	V_{OL}	$I_{OL} = 400\ \mu\text{A}$			0.4	V	
Output 'High' voltage	V_{OH}	$I_{OH} = -100\ \mu\text{A}$	$0.8 \times V_{CC}$			V	
Input leakage current	$ I_{LI} $	$V_{IN} = 0\text{ V}$ to V_{CC}			10	μA	
Output leakage current	$ I_{LO} $	$V_{OUT} = 0\text{ V}$ to V_{CC}			10	μA	1
Operating current	I_{CC}	$t_{RC} = 500\text{ ns}$			18	mA	2
Standby current	I_{SB}	$\overline{CE} = V_{CC} - 0.2\text{ V}$			30	μA	
Input capacitance	C_{IN}	$f = 1\text{ MHz}$			10	pF	
Output capacitance	C_{OUT}	$T_A = 25^\circ\text{C}$			10	pF	

NOTE:

- $\overline{CE}/\overline{OE} = V_{IH}$, $OE = V_{IL}$
- Outputs open

AC CHARACTERISTICS ($V_{CC} = 2.6\text{ V}$ to 3.6 V , $T_A = 0^\circ\text{C}$ to $+70^\circ\text{C}$)

PARAMETER	SYMBOL	MIN.	MAX.	UNIT	NOTE
Read cycle time	t_{RC}	500		ns	
Address access time	t_{AA}		500	ns	
Chip enable access time	t_{ACE}		500	ns	
Output enable delay time	t_{OE}		200	ns	
Output hold time	t_{OH}	10		ns	
CE to output in High-Z	t_{CHZ}		150	ns	1
OE to output in High-Z	t_{OHZ}			ns	

NOTE:

- This is the time required for the output to become high-impedance.

AC TEST CONDITIONS

PARAMETER	RATING
Input voltage amplitude	0.4 V to $(0.8 \times V_{CC})$ V
Input rise/fall time	10 ns
Input/output reference level	1.5 V
Output load condition	1TTL + 100 pF

CAUTION

To stabilize the power supply, it is recommended that a high-frequency bypass capacitor be connected between the V_{CC} pin and the GND pin.

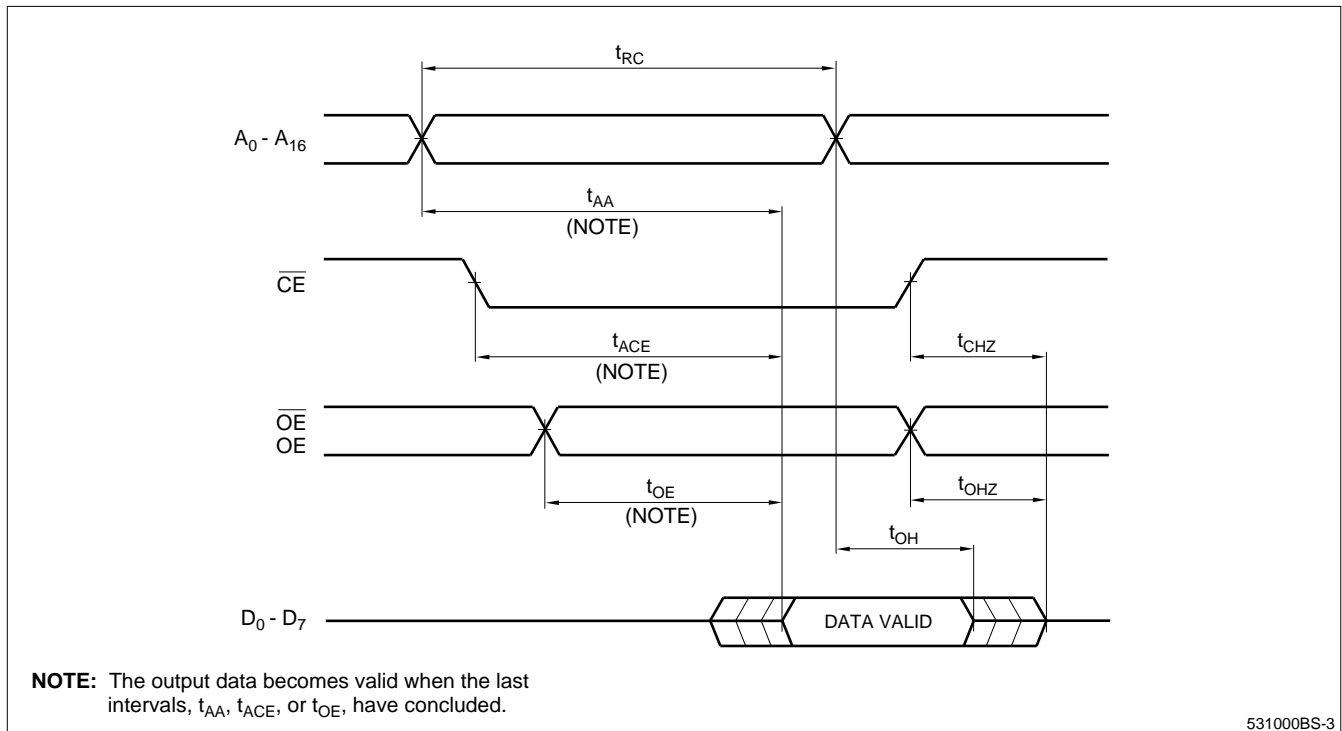
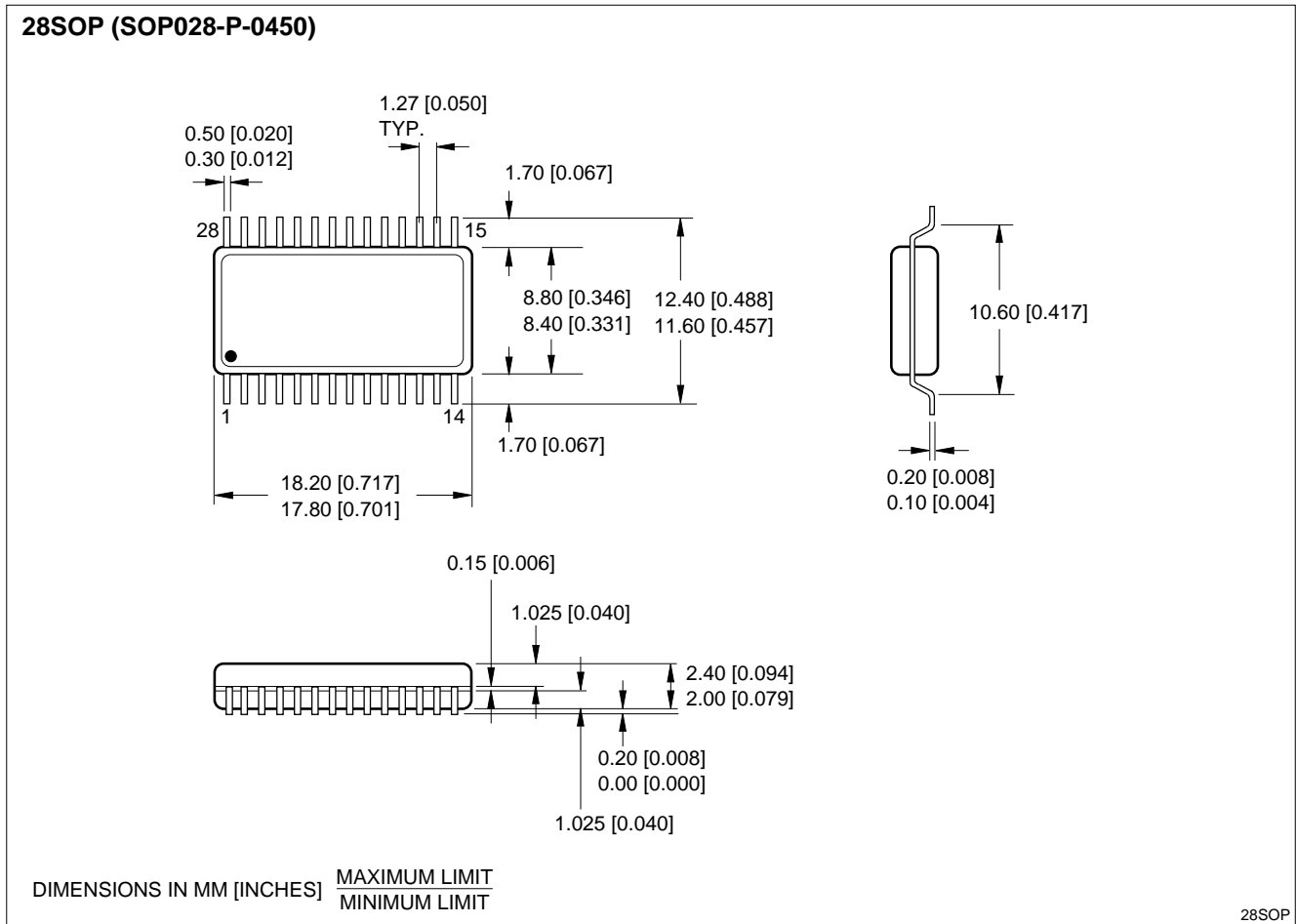

Figure 3. Timing Diagram

PACKAGE DIAGRAM



28-pin, 450-mil SOP

ORDERING INFORMATION

